

SCS-103A-EN

Fire Protected Ceiling Speaker



Features:

- Steel fire protection dome
- Two power taps
- Steel front grill
- Flame retardant materials
- Ceramic connection block
- Thermal fuse

Applications:

- All applications where built-in speakers are needed for evacuation purposes

The **SCS-103A-EN** is a fire-protected ceiling speaker with a 5" cone, capable of producing a power of 3 W.

It ensures a good reproduction of speech and alarm signals for evacuation purposes. It is fitted with a 100V line transformer with power tap for 3 W to be used in large 100V PA systems.

The speaker is equipped with a special steel fire protection dome fitted around the speaker and a steel front grill with flame retardant materials.

The connections of the loudspeaker are performed using a ceramic connection block and the thermal fuse ensures that in case of fire the loudspeaker will be disconnected from the circuit. Hereby, the other loudspeakers on the same circuit will keep on operating.

Dimensions:

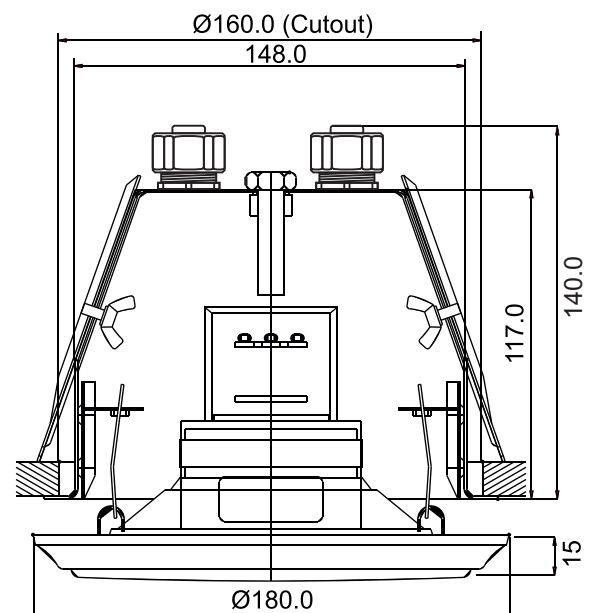

SCS-103A-EN

Fire Protected Ceiling Speaker

Technical Specifications:

Power Handling	3 watts
Rated Input	100 volt
Transformer Tapping	3 watts
SPL (1w/1m)	92dB
Max SPL (rated/1m)	98 ± 3dB
Frequency Response	265Hz – 20kHz
Dispersion 1kHz/4kHz	160/ 78
Dimensions (diameter x depth)	180mm x 140mm
Cutout Size (diameter)	160mm
Material	Steel
Weight (inc. packaging)	1.70 kg
Colour	White RAL9003

Polar Pattern:

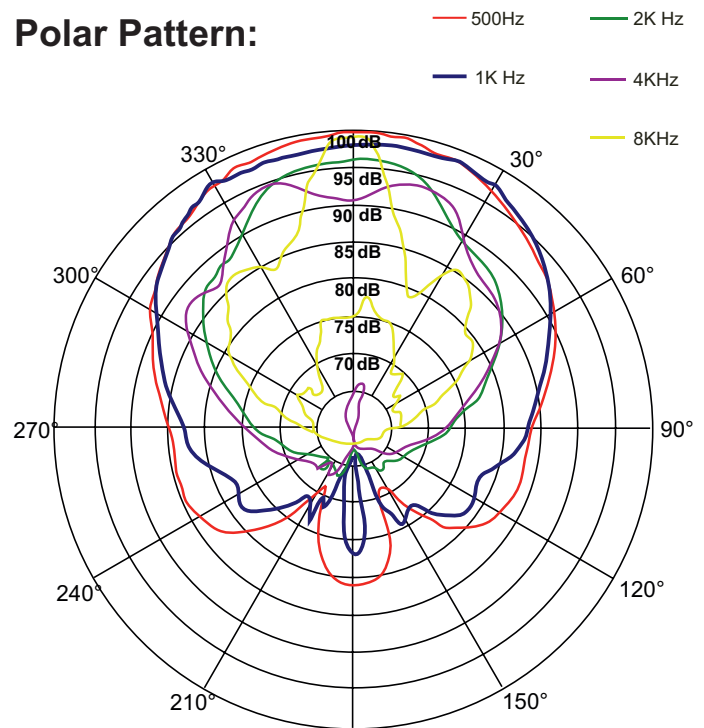

Frequency Response:

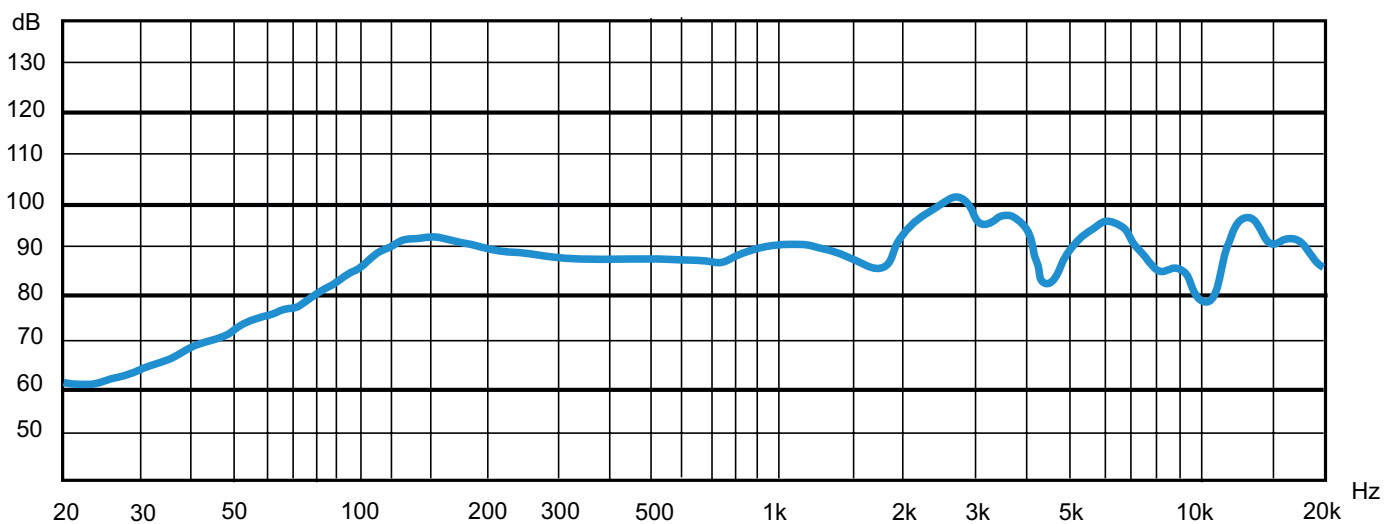

SCS-103A-EN

Fire Protected Ceiling Speaker

Wiring:

Connect the lead-in cable (the one from the amplifier) to the screw terminal. In this case, bend the cables as shown below to facilitate the cable insertion into the input terminals.

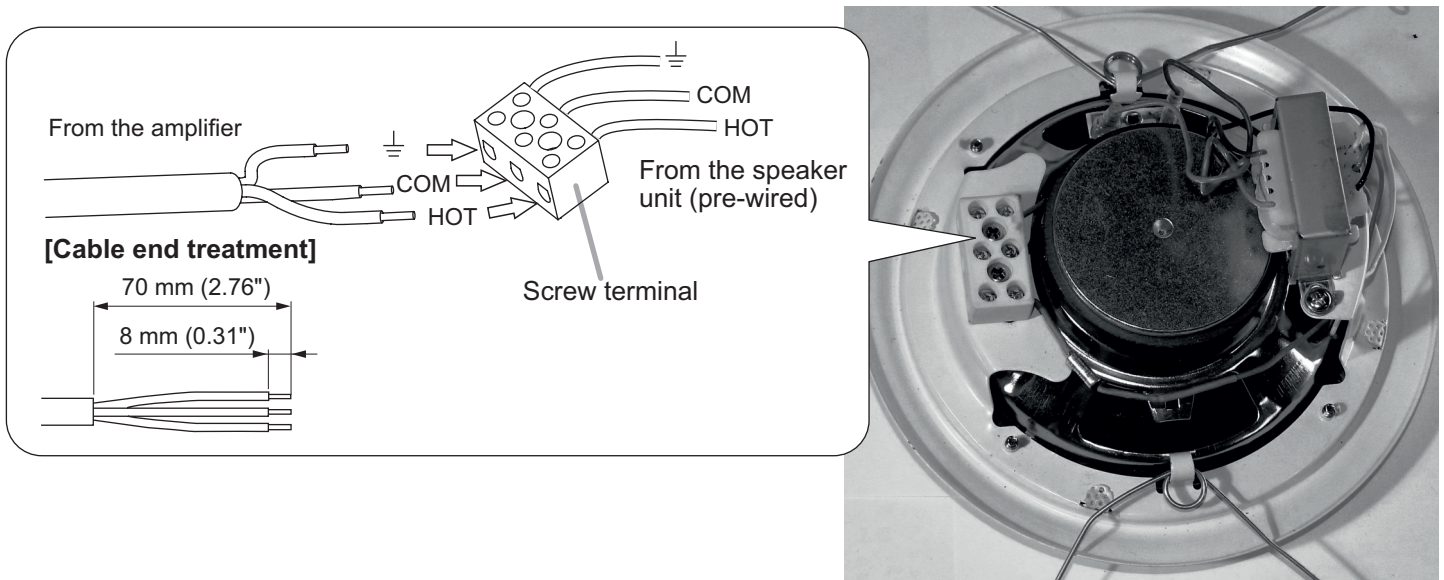

When connecting the lead-out cable (the one to the next speaker), connect both the lead-in and leadout cables of the same polarity to each corresponding input terminal.

Viewed from the screw terminal's bottom side

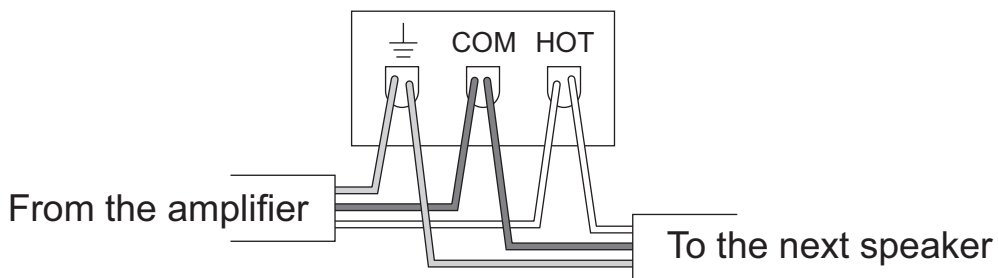

Wiring Diagram:

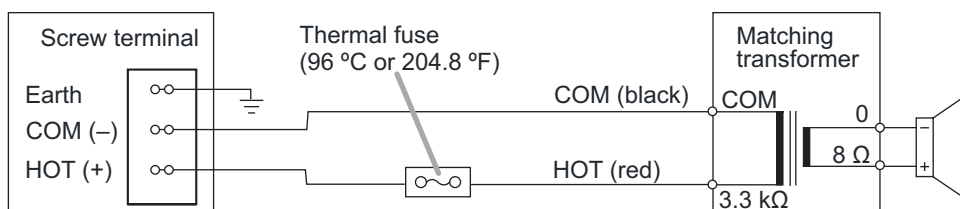

SCS-103A-EN

Fire Protected Ceiling Speaker

Installation Procedure:

1) Cut a hole in the ceiling, on the desired mounting location of the loudspeaker, with a diameter of 160mm.

2) Remove the loudspeaker out of the firedome. The loudspeaker is fixed in the firedome by means of two mounting springs. It can be removed by pulling the white front grill away from the firedome. It will come out easily, without performing large forces.

3) After the loudspeaker comes out the firedome, it still will be suspended by the two springs. Release the two springs by pressing them together. Now the speaker can be completely removed from the firedome.

4) Take the firefome, and release the two wing bolts on the inner side of the firedome. Slide the two fixing plates upwards. This allows the firedome to be pushed inside the ceiling hole. Before you push the firedome through the mounting hole in the ceiling, make sure that the speaker connection cable is provided through the holes in the firedome. A mounting bolt is provided on top of the firedome. This allows to connect a steel safety wire to the firedome. This can be used for additional security purposes.

5) When the firedome is pushed up inside the fixing hole, slide the two fixing plates down by means of the wing bolts. The ceiling will be clamped between the edge of the firedome, and the fixing plates. After tightening the two wing bolts, the firedome will be hold in place.

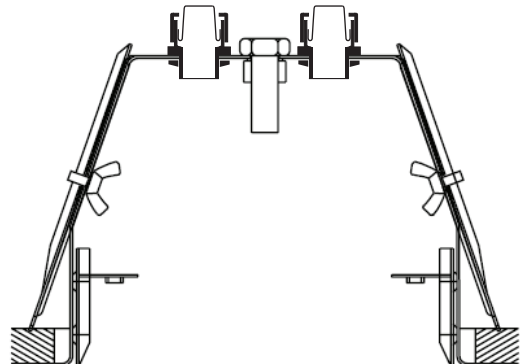
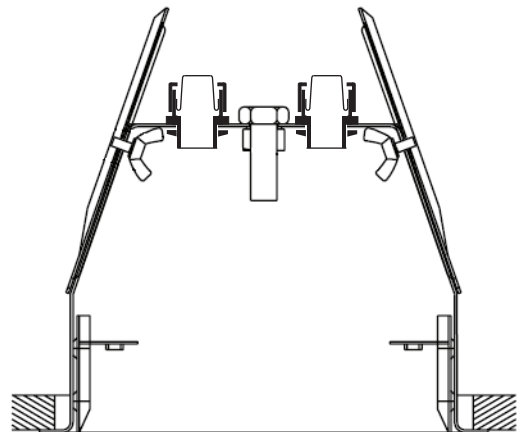
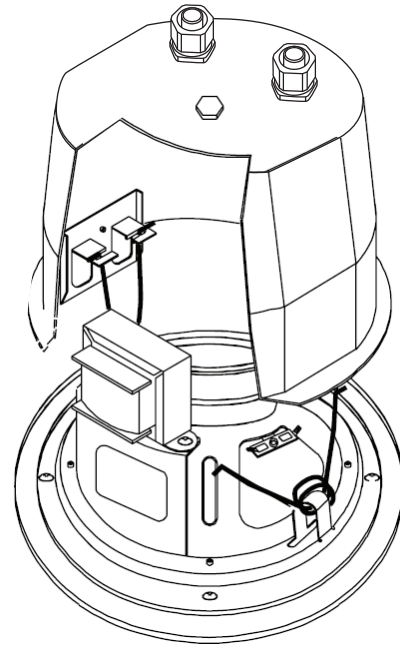

SCS-103A-EN

Fire Protected Ceiling Speaker

Installation Procedure:

6) Suspend the loudspeaker on one side of the fire dome. This can be done by pressing the mounting springs together and attach them to one of the side brackets on the inner side of the fire dome.

7) Connect the loudspeaker connection cable to the provided ceramic connection block. Always connect the common to the COM connection terminal. And the positive amplifier output can be connected to 3 Watt (HOT) connection terminal.

8) When the connections are made, connect the second mounting clip to the speakers fire dome. The loudspeaker will slide nicely into the fire dome by applying only a small force on the speakers grill.

